

TMC2490A/TMC2491A

Multistandard Digital Video Encoder

Features

- All-digital video encoding
- Internal digital subcarrier synthesizer
- 8-bit parallel CCIR-601/CCIR-656/ANSI/SMPTE 125M input format
- CCIR-624/SMPTE-170M compliant output
- Switchable chrominance bandwidth
- Switchable pedestal with gain compensation
- Pre-programmed horizontal and vertical timing
- 13.5 Mpps pixel rate
- Master or slave (CCIR656) operation
- MPEG interface
- Internal interpolation filters simplify output reconstruction filters
- 10-bit D/A converters for video reconstruction
- Supports NTSC and PAL standards
- Output encoding per Macrovision Copy Protection (Revision 7.01) available (TMC2491A)
- Closed-caption waveform insertion
- Simultaneous S-Video (Y/C) output
- Controlled edge rates
- Single +5V power supply
- 44 lead PLCC package
- Parallel and serial control interface

Applications

- Set-top digital cable television receivers
- Set-top digital satellite television receivers
- Studio parallel CCIR-601 to analog conversion

Description

The TMC2490(1)A video encoder converts digital component video (in 8-bit parallel CCIR-601/656 or ANSI/SMPTE 125M format) into a standard analog baseband television (NTSC, NTSC-EIA, and all PAL standards) signal with a modulated color subcarrier. Both composite (single lead) and S-Video (separate chroma and luma) formats are active simultaneously at all three analog outputs. Each video output generates a standard video signal capable of driving a singly- or doubly-terminated 75 Ohm load.

The TMC2491A is intended for those applications like DVD or set-top boxes where Macrovision 7.01 compliance is required. The TMC2490A is intended for all other non-Macrovision encoder applications. A separate data sheet supplement is available to Macrovision licensees.

The TMC2490(1)A is fabricated in a submicron CMOS process and is packaged in a 44-lead PLCC. Performance is guaranteed over the full 0°C to 70°C operating temperature range.

Block Diagram

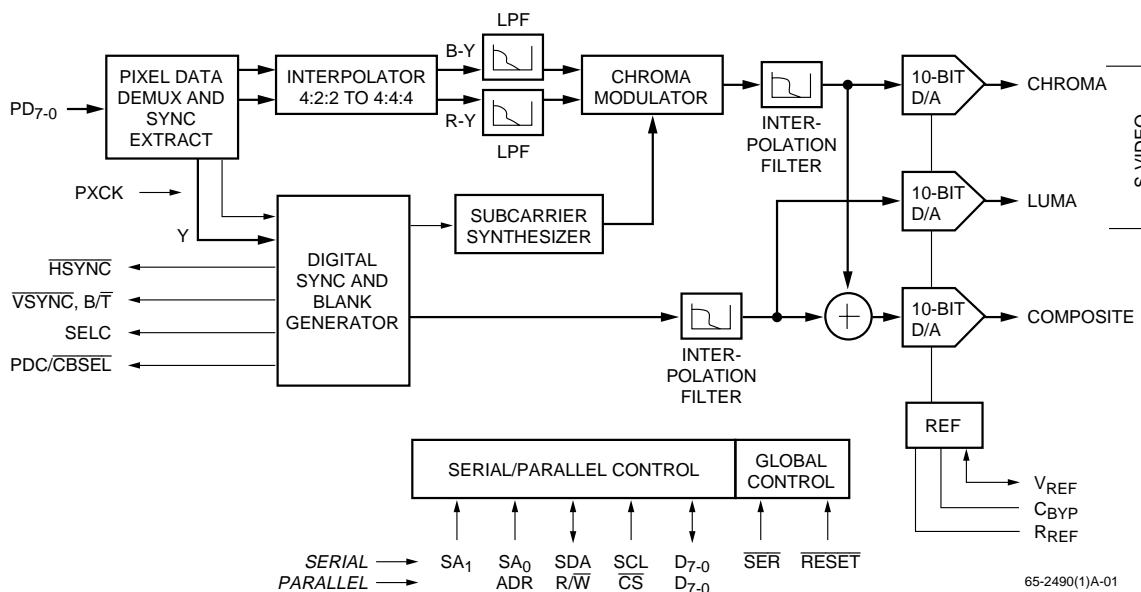

Preliminary Information

Functional Description

The TMC2490(1)A is a fully-integrated digital video encoder with simultaneous composite and Y/C (S-Video) outputs, compatible with NTSC, NTSC-EIA, and all PAL television standards.

Digital component video is accepted at the PD port in 8-bit parallel CCIR-601/656 format. It is demultiplexed into luminance and chrominance components. The chrominance components modulate a digitally synthesized subcarrier. The luminance and chrominance signals are then separately interpolated to twice the input pixel rate and converted to analog signals by 10-bit D/A converters. They are also digitally combined and the resulting composite signal is output by a third 10-bit D/A converter.

The TMC2490(1)A operates from a single clock at 27 MHz, twice the system pixel rate. Programmable control registers allow software control of subcarrier frequency and phase parameters. Incoming YC_BCR422 digital video is interpolated to YC_BCR444 format for encoding.

Internal control registers can be accessed over a standard 8-bit parallel microprocessor port or a 2-pin (clock and data) serial port.

Sync Generator

The TMC2490(1)A operates in master or slave mode. In slave mode, it extracts its horizontal and vertical sync timing and field information from the CCIR-656 SAV (Start of Active Video) and EAV (End of Active Video) signal in the incoming data stream. In master mode, it generates a 13.5 MHz timebase and sends line and field synchronizing signals to the host system.

Horizontal and vertical synchronization pulses in the analog output are digitally generated by the TMC2490(1)A with controlled rise and fall times on all sync edges, the beginning and end of active video, and the burst envelope.

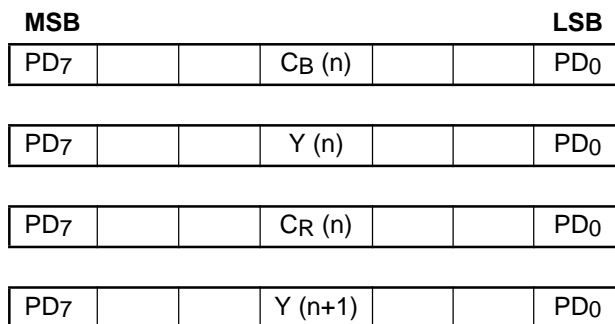

Figure 1. Pixel Data Format

Chroma Modulator

A digital subcarrier synthesizer generates the reference for a quadrature modulator, producing a digital chrominance signal. The chroma bandwidth may be programmed to 650 kHz or 1.3 MHz.

Interpolation Filters

Interpolation filters on the luminance and chrominance signals double the pixel rate to 27Mpps before D/A conversion. This low-pass filtering and oversampling process reduces $\sin(x)/x$ roll-off, and greatly simplifies the analog reconstruction filter required after the D/A converters.

D/A Converters

Analog outputs of the TMC2490(1)A are driven by three 10-bit D/A converters. The outputs drive standard video levels into 37.5 or 75 Ohm loads. An internal voltage reference is used to provide reference current for the D/A converters. An external fixed or variable voltage reference source can also be used. The video signal levels from the TMC2490(1)A may be adjusted to overcome the insertion loss of analog low-pass output filters by varying RREF or VREF.

Macrovision 7.01

To deter unauthorized video taping, the output data stream can be modified per the Macrovision antitaping process (Revision 7.01). The TMC2491A data sheet supplement contains information on the application of Macrovision antitaping process (Revision 7.01). Only Macrovision licensees will be able to receive this information.

Parallel and Serial Microprocessor Interfaces

The parallel microprocessor interface employs 11 pins. These are shared with the serial interface. A single pin, $\overline{\text{SER}}$, selects between the two interface modes.

In parallel interface mode, one address pin is decoded to enable access to the internal control register and its pointer. Controls are reached by loading a desired address through the 8-bit D7-0 port, followed by the desired data (read or write) for that address. The control register address pointer auto-increments to address 22h and then remains there.

A 2-line serial interface is also provided on the TMC2490(1)A for initialization and control. The same set of registers accessed by the parallel port is available to the serial port.

The $\overline{\text{RESET}}$ pin sets all internal state machines and control registers to their initialized conditions, disables the analog outputs, and places the encoder in a reset mode. At the rising edge of $\overline{\text{RESET}}$, the encoder is automatically initialized in NTSC-M format.

Pin Assignments

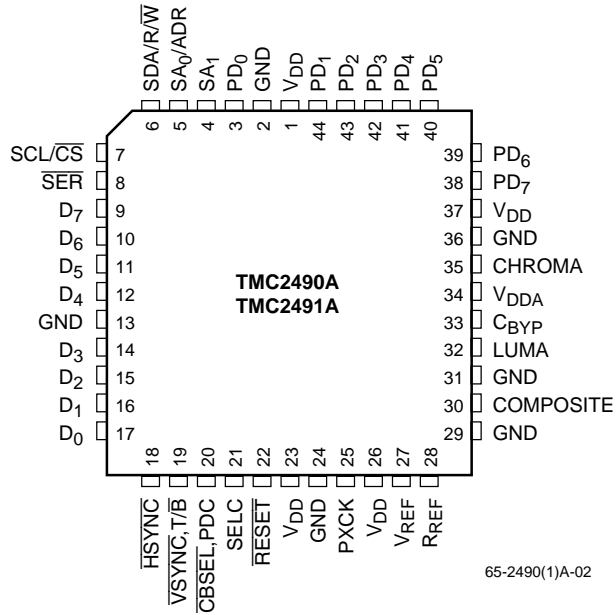

Pin Descriptions

Pin Name	Pin Number	Value	Pin Function Description
Clock			
PXCK	25	TTL	Pixel Clock Input. This 27.0 MHz clock is internally divided by 2 to generate the internal pixel clock. PXCK drives the entire TMC2490(1)A, except the asynchronous microprocessor interface. All internal registers are strobed on the rising edge of PXCK.
Data Input Port			
PD7-0	38–44, 3	TTL	Pixel Data Inputs. Video data enters the TMC2490(1)A on PD7-0 (Figure 1).
Microprocessor Interface			
D7-0	9–12, 14–17	TTL	Data I/O, General Purpose I/O, Chroma Input Port. When SER is HIGH, all control parameters are loaded into and read back over this 8-bit port. When SER = LOW, D0 can serve as a composite sync output, D1 outputs a burst flag during the back porch, D2-5 are General Purpose Outputs, and D6-7 are General Purpose Inputs.
RESET	22	TTL	Master Reset Input. Bringing RESET LOW forces the internal state machines to their starting states and disables all outputs.
SA1	4	TTL	Serial/Parallel Port Select. When SER is LOW, SA1 in conjunction with SA0 selects one of four addresses for the TMC2490(1)A.
SA0, ADR	5	TTL	Serial/Parallel Port Select. When SER is LOW, SA0 in conjunction with SA1 selects one-of-four addresses for the TMC2490(1)A. When SER is HIGH, this control governs whether the parallel microprocessor interface selects a table address or reads/writes table contents.

Pin Descriptions (continued)

Pin Name	Pin Number	Value	Pin Function Description
SDA, R/W	6	R-Bus/TTL	Serial Data/Read/Write Control. When $\overline{\text{SER}}$ is LOW, SDA is the data line of the serial interface. When $\overline{\text{SER}}$ is HIGH, the pin is the read/write control for the parallel interface. When R/W and $\overline{\text{CS}}$ are LOW, the microprocessor can write to the control registers over D7-0. When R/W is HIGH and $\overline{\text{CS}}$ is LOW, it can read the contents of any selected control register over D7-0.
SCL, $\overline{\text{CS}}$	7	R-Bus/TTL	Serial Clock/Chip Select. When $\overline{\text{SER}}$ is LOW, SCL is the clock line of the serial interface. When $\overline{\text{SER}}$ is HIGH, the pin is the chip select control for the parallel interface. When $\overline{\text{CS}}$ is HIGH, the microprocessor interface port, D7-0, is set to HIGH impedance and ignored. When $\overline{\text{CS}}$ is LOW, the microprocessor can read or write parameters over D7-0.
$\overline{\text{SER}}$	8	TTL	Serial/Parallel Port Select. When LOW, the 2-line serial interface is activated. Pins 5, 6, and 7 function as SA0, SDA, and SCL respectively. When HIGH, the parallel interface port is active and pins 5, 6, and 7 function as ADR, R/W, and $\overline{\text{CS}}$ respectively.
Outputs			
CHROMA	35	1.35V p-p	Chrominance-only Video. Analog output of chrominance D/A converter. Maximum output is 1.35 volts peak-to-peak into a doubly terminated 75 Ohm load.
COMPOSITE	30	1.35V p-p	Composite NTSC/PAL Video. Analog output of composite D/A converter. Maximum output is 1.35 volts peak-to-peak into a doubly terminated 75 Ohm load.
LUMA	32	1.35V p-p	Luminance-only Video. Analog output of luminance D/A converter. Maximum output is 1.35 volts peak-to-peak into a doubly terminated 75 Ohm load.
Analog Interface			
CBYP	33	0.1 μ F	Reference Bypass Capacitor. Connection point for 0.1 μ F decoupling capacitor to VDD at pin 34.
RREF	28	787 Ω	Current-setting Resistor. Connection point for external current-setting resistor for D/A converters. The resistor is connected between RREF and GND. Output video levels are inversely proportional to the value of RREF.
VREF	27	+1.235V	Voltage Reference Input. External voltage reference input, internal voltage reference output, nominally 1.235 V.
SYNC Out			
$\overline{\text{HSYNC}}$	18	TTL	Horizontal Sync Output.
$\overline{\text{VSYNC}}$, T/B	19	TTL	Vertical Sync Output or Odd/Even Field ID Output.
$\overline{\text{CBSEL}}$, PDC	20	TTL	Pixel Data Phase Output or Video Blanking Output.
SELC	21	TTL	Luma/Chroma MUX Control.
Power Supply			
VDD	1, 23, 26, 37	+5V	Power Supply. Positive power supply.
GND	2, 13, 24, 29, 31, 36	0.0V	Ground.
VDDA	34	+5V	Analog Power Supply. Positive power supply.

Control Registers

The TMC2490(1)A is initialized and controlled by a set of registers which determine the operating modes.

An external controller is employed to write and read the Control Registers through either the 8-bit parallel or 2-line

serial interface port. The parallel port, D7-0, is governed by pins \overline{CS} , R/\overline{W} , and ADR. The serial port is controlled by SDA and SCL.

Table 1. Control Register Map

Reg	Bit	Mnemonic	Function
TMC2490(1)A Identification Registers (Read only)			
00	7-0	PARTID2	Reads back 97h
01	7-0	PARTID1	Reads back 24h
02	7-0	PARTID0	Reads back 90h (91h)
03	7-0	REVID	Silicon revision #
Global Control Register			
04	7	MASTER	Master Mode
04	6	NGSEL	NTSC Gain Select
04	5	YCDELAY	Luma to chroma delay
04	4	RAMPEN	Modulated ramp enable
04	3	YCDIS	LUMA, CHROMA disable
04	2	COMPDIS	COMPOSITE disable
04	1-0	FORMAT	Television standard select
Video Output Control Register			
05	7	PALN	Select PAL-N Subcarrier
05	6	\overline{BURSTF}	Burst flag disable
05	5	CHRBW	Chroma bandwidth select
05	4	SYNCDIS	Sync pulse disable
05	3	BURDIS	Color burst disable
05	2	LUMDIS	Luminance disable
05	1	CHRDIS	Chrominance disable
05	0	PEDEN	Pedestal enable
Field ID Register			
06	7-6	Reserved	Program LOW
06	5-3	FIELD	Field ID (Read only)
06	2-0	Reserved	Program LOW
Reserved Registers			
07-0D	7-0	Reserved	Program LOW

Reg	Bit	Mnemonic	Function
General Purpose Port Register			
0E	7	PORT7-6	General purpose Inputs
0E	6	PORT5-2	General purpose Outputs
0E	1	BURSTF	Burst Flag Output
0E	0	CSYNC	Composite Sync Output
General Control Register			
0F	7	PED21	VBI Pedestal Enable
0F	5	VSEL	Vertical Sync Select
0F	4	CBSEL	CBSEL/PDC Pin Function
0F	3	VBIEN	VBI Pixel Data Enable
0F	1-0	HDSEL	HSYNC Delay
Reserved Registers			
10-1F	7-0	Reserved	May be left unprogrammed
Closed-Caption Insertion Registers			
20	7-0	CCD1	First Byte of CC Data
21	7-0	CCD2	Second Byte of CC Data
22	7	CCON	Enable CC Data Packet
22	6	CCRTS	Request To Send Data
22	5	CCPAR	Auto Parity Generation
22	4	CCFLD	CC Field Select
22	3-0	CCLINE	CC Line Select

Notes:

1. For each register listed above, all bits not specified are reserved and should be set to logic LOW to ensure proper operation.

Preliminary Information

Table 2. Default Register Values on Reset

Reg	Dflt	Reg	Dflt	Reg	Dflt	Reg	Dflt	Reg	Dflt
00	97	04	00	08	00	0C	00	20	80
01	24	05	01	09	00	0D	00	21	80
02	90(91)	06	00	0A	00	0E	00	22	00
03	xx	07	00	0B	00	0F	F2		

Control Register Definitions

Reg	Bit	Name	Description
00	7–0	PARTID2	Reads back 97h
01	7–0	PARTID1	Reads back 24h
02	7–0	PARTID0	Reads back 90h (91h)
03	7–0	REVID	Reads back a value corresponding to the revision letter of the silicon.

Global Control Register (04)

7	6	5	4	3	2	1	0
MASTER	NGSEL	YCDELAY	RAMPEN	YCDIS	COMPDIS	FORMAT	

Reg	Bit	Name	Description
04	7	MASTER	Master Mode. When MASTER = 1, the encoder generates its own video timing and outputs signals \overline{VSYNC} (or T/B), \overline{HSYNC} , SELC, and PDC (or CBSEL). When MASTER = 0, the TMC2490(1)A extracts timing from the embedded EAV codeword in the video datastream and optionally outputs signals \overline{VSYNC} (or T/B), \overline{HSYNC} , SELC, and PDC (or CBSEL).
04	6	NGSEL	NTSC Gain Selection.
04	5	YCDELAY	Luma to chroma delay. When HIGH, the luminance path within the TMC2490(1)A is delayed by one PXCK period. The delay applies to both COMPOSITE and LUMA outputs and may be used to compensate for group delay variation of external filters. When LOW, luminance and chrominance have the same latency.
04	4	RAMPEN	Modulated ramp enable. When HIGH, the TMC2490(1)A outputs a modulated ramp test signal. When LOW, incoming digital video is encoded.
04	3	YCDIS	LUMA, CHROMA disable. When HIGH, the LUMA and CHROMA outputs are disabled. Set LOW for normal enabled operation.
04	2	COMPDIS	COMPOSITE disable. When HIGH, the COMPOSITE output is disabled. Set LOW for normal enabled operation.
04	1–0	FORMAT	Television standard select. Selects basic H&V timing parameters and subcarrier frequency. Pedestal level and chrominance bandwidth are independently programmed. 0 0 NTSC 0 1 PAL-B,G,H,I,N 1 0 PAL-M 1 1 Reserved

Control Register Definitions (continued)

Video Output Control Register (05)

7	6	5	4	3	2	1	0
PALN	$\overline{\text{BURSTF}}$	CHRBW	SYNCDIS	BURDIS	LUMDIS	CHRDIS	PEDEN

Reg	Bit	Name	Description
05	7	PALN	Select PAL-N Subcarrier. When HIGH, selects PAL-N subcarrier frequency. When LOW, the encoder produces the PAL-B,G,H,I subcarrier. Program LOW for NTSC and PAL-M video.
05	6	$\overline{\text{BURSTF}}$	Burst flag disable. When $\overline{\text{BURSTF}}$ is LOW, a clamp gate signal is produced on the D1 output and register 0E bit 1.
05	5	CHRBW	Chroma bandwidth select. When LOW, the chrominance bandwidth is ± 650 kHz. When HIGH, the chrominance bandwidth is ± 1.3 MHz.
05	4	SYNCDIS	Sync pulse disable. When HIGH, horizontal and vertical sync pulses on the COMPOSITE video output are suppressed (to blanking level). Color burst, active video, and the CSYNC output remain active. Set LOW for normal composite video operation.
05	3	BURDIS	Color burst disable. When HIGH, color burst is suppressed to the blanking level. Set LOW for normal operation.
05	2	LUMDIS	Luminance disable. When HIGH, incoming Y values are forced to black level. Color burst, CHROMA, and sync are not affected. Set LOW for normal operation.
05	1	CHRDIS	Chrominance disable. When HIGH, incoming color components C_B and C_R are suppressed, enabling monochrome operation. Output color burst is not affected. Set LOW for normal color operation.
05	0	PEDEN	Pedestal enable. When LOW, black and blanking are the same level for ALL lines. When HIGH, a 7.5 IRE pedestal is inserted into the output video for NTSC and PAL-M lines 23-262 and 286-525 only. Chrominance and luminance gain factors are adjusted to keep video levels within range. PEDEN is valid for NTSC and PAL-M only and should be LOW for all other formats.

Field Data Register (06)

7	6	5	4	3	2	1	0
Reserved		FIELD			Reserved		

Reg	Bit	Name	Description
06	7-6	Reserved	Program LOW.
06	5-3	FIELD	Field ID (Read only). A value of 000 corresponds to field 1 and 111 corresponds to field 8.
06	2-0	Reserved	Program LOW.

Control Register Definitions (continued)

Reserved Registers (07–0D)

7	6	5	4	3	2	1	0
Reserved							

Reg	Bit	Name	Description
07–0D	7–0	Reserved	Program LOW.

General Purpose Port Register (0E)

7	6	5	4	3	2	1	0
PORT7	PORT6	PORT5	PORT4	PORT3	PORT2	BURSTF	CSYNC

Reg	Bit	Name	Description
0E	7–6	PORT7–6	General purpose Inputs. When in serial control mode, these register read-only bits indicate the state present on data port pins D7 and D6.
0E	5–2	PORT5–2	General purpose Outputs. When in serial control mode or when reading register 0E in parallel control mode, these register read/write bits drive data pins D5–D2 to the state contained in the respective register bits.
0E	1	BURSTF	Burst Flag Output. Produces Burst Flag on data pin D1 when in serial control mode, or when reading register 0E.
0E	0	CSYNC	Composite Sync Output. Produces Composite Sync on data pin D0 when in serial control mode, or when reading register 0E.

Control Register Definitions (continued)

General Control Register (0F)

7	6	5	4	3	2	1	0
PED21	Reserved	VSEL	CBSEL	VBIEN	Reserved		

Reg	Bit	Name	Description
0F	7	PED21	VBI Pedestal Enable. When HIGH and FORMAT is 00 (NTSC) or 10 (PAL-M), pedestal is added to lines 21, 22, 283, 284, 285. When LOW, no pedestal is placed on these lines. PED21 is valid for NTSC and PAL-M only and should be LOW for all other formats.
0F	6	Reserved	Program HIGH.
0F	5	VSEL	Vertical Sync Select. When LOW, the TMC2490(1)A outputs a traditional vertical sync on $\overline{\text{VSYNC}}$. When HIGH, the chip outputs odd/even field identification on the $\overline{\text{VSYNC}}$ pin, with 0 denoting an odd field.
0F	4	CBSEL	CBSEL/PDC pin function. When CBSEL = 0, the PDC signal is produced on the CBSEL/PCD pin. When CBSEL = 1, the CBSEL signal is produced on the CBSEL/PDC pin.
0F	3	VBIEN	VBI Pixel Data Enable. When VBIEN = 0, the vertical interval lines are blanked. When VBIEN = 1, Pixel data is encoded into the VBI lines.
0F	2	Reserved	Program LOW.
0F	1–0	HDEL	Sync Delay. HDEL shifts the falling edge of the H and V syncs relative to the PD port. HDEL Result 00 H and V syncs are aligned with luminance pixel 735 (Y735) 01 H and V syncs are aligned with Blue color difference pixel 735 (Cb736) 10 H and V syncs are aligned with luminance pixel 736 (Y736) 11 H and V syncs are aligned with Red color difference pixel 735 (Cr736) Refer to Figure 2a, HDEL Timing

Reserved Registers (10–1F)

7	6	5	4	3	2	1	0
Reserved							

Reg	Bit	Name	Description
10–1F	7–0	Reserved	May be left unprogrammed

Control Register Definitions (continued)

Closed-Caption Insertion (20)

7	6	5	4	3	2	1	0
CCD1							

Reg	Bit	Name	Description
20	7-0	CCD1	First Byte of CC Data. Bit 0 is the LSB. The MSB will be overwritten by an ODD Parity bit if CCPAR is HIGH.

Closed-Caption Insertion (21)

7	6	5	4	3	2	1	0
CCD2							

Reg	Bit	Name	Description
21	7-0	CCD2	Second Byte of CC Data. Bit 0 is the LSB. The MSB will be overwritten by an ODD Parity bit if CCPAR is HIGH.

Closed-Caption Insertion (22)

7	6	5	4	3	2	1	0
CCON	CCRTS	CCPAR	CCFLD	CCLINE			

Reg	Bit	Name	Description
22	7	CCON	Enable CC Data Packet. Command the CC data generator to send either CC data or a NULL byte whenever the specified line is transmitted.
22	6	CCRTS	Request To Send Data. This bit is set HIGH by the user when bytes 20 and 21 have been loaded with the next two bytes to be sent. When the encoder reaches the falling edge of the HSYNC preceding the line specified in bits 4-0 of this register, data will be transferred from registers 20 and 21, and RTS will be reset LOW. A new pair of bytes may then be loaded into registers 20 and 21. If CCON = 1 and CCRTS = 0 when the CC line is to be sent, NULL bytes will be sent.
22	5	CCPAR	Auto Parity Generation. When set HIGH, the encoder replaces the MSB of bytes 20 and 21 with a calculated ODD parity. When set LOW, the CC processor transmits the 16 bits exactly as loaded into registers 20 and 21.
22	4	CCFLD	CC Field Select. When LOW, CC data is transmitted on the selected line of ODD fields. When HIGH, it is sent on EVEN fields.
22	3-0	CCLINE	CC Line Select. Defines (with an offset) the line on which CC data is transmitted.

General Purpose Port

The TMC2490(1)A provides a general purpose I/O port for system utility functions. Input, output, and sync functions are implemented. Register 0E is the General Purpose Register.

Full functionality is provided when the encoder is in Serial control mode ($\overline{\text{SER}} = \text{LOW}$). Most of the functions are available in parallel interface mode ($\overline{\text{SER}} = \text{HIGH}$).

General Purpose Input (serial mode only)

Bits 7 and 6 of Register 0E are general purpose inputs. When the encoder is in serial control mode, data bits D7 and D6 are mirrored to these register locations. When Register 0E is read, the states of bits 7 and 6 reflect the TTL logic levels present on D7 and D6, respectively, at the time of read command execution. Writing to these bits has no effect.

This function is not available when the encoder is in parallel control mode.

General Purpose Output

Register 0E read/write bits 5-2 are connected to pins D5-2, respectively, when the encoder is in serial control mode. The output pins continually reflects the values most recently written into register 0E (1 = HIGH, 0 = LOW). Note that these pins are always driven outputs when the encoder is in serial control mode.

When register 0E is read, these pins report the values previously stored in the corresponding register bits, i.e., it acts as a read/write register. When the encoder is in parallel control mode, this reading produces the output bit values on the corresponding data pins, just as in the serial control mode. However, the values are only present when reading register 0E. The controller can command a continuous read on this register to produce continuous outputs from these pins.

Burst Flag and Composite Sync (output/read-only)

Register 0E bit 1 is associated with the encoder burst flag. It is a 1 (HIGH) from just before the start of the color burst to just after the end of the burst. It is a 0 (LOW) at all other times.

Register 0E bit 0 outputs the encoder composite sync status. It is a 0 (LOW) during horizontal and vertical sync tips. It is a 1 (HIGH) at all other times.

These register bits may be read at any time over either the serial or parallel control port. Since they are dynamic, their states will change as appropriate during a parallel port read. In fact, if the parallel control port is commanded to read register 0E continually, the pins associated with these bits behave as burst flag and composite sync timing outputs.

In serial control mode, these same data output pins (D1-0) always act as a burst flag and composite sync TTL outputs, the conditions of the serial control notwithstanding. The states of the flags may be read over the serial port, but due to the low frequency of the serial interface, it may be difficult to get meaningful information.

Pixel Interface

The TMC2490(1)A interfaces with an 8-bit 13.5 Mpps (27 MHz) video datastream. It will automatically synchronize with embedded Timing Reference Signals, per CCIR-656. It also includes a master sync generator on-chip, which can produce timing reference outputs.

CCIR-656 Mode

When operating in CCIR-656 Mode (MASTER = 0), the TMC2490(1)A identifies the SAV and EAV 4-byte code-words embedded in the video datastream to derive all timing. Both SAV and EAV are required.

MASTER Mode

When in MASTER Mode (MASTER = 1), the Encoder produces its own timing, and provides $\overline{\text{HSYNC}}$, $\overline{\text{VSYNC}}$ (or $\overline{\text{B/T}}$), SELC, and PDC (or $\overline{\text{CBSEL}}$) to the Pixel Data Source.

SELC Output

The SELC output toggles at 13.5 MHz (1/2 the pixel rate), providing a phase reference for the multiplexed luma/chroma CCIR-656 datastream. It is HIGH during the rising edge of the clock intended to load chroma data. This is useful when interfacing with a 16-bit data source, and can drive a Y/C multiplexer.

CBSEL Output

The CBSEL output identifies the CB element of the $\text{C}_B\text{-Y-C}_R\text{-Y}$ CCIR-656 data sequence. It is HIGH during the rising edge of the clock to load C_B data. This will prevent unintentionally swapping the C_B and C_R color components when operating in MASTER mode and reading data from a framestore.

PDC Output

The PDC output is a blanking signal, indicating when the encoder expected to receive pixel data. When PDC is HIGH, the incoming PD is encoded.

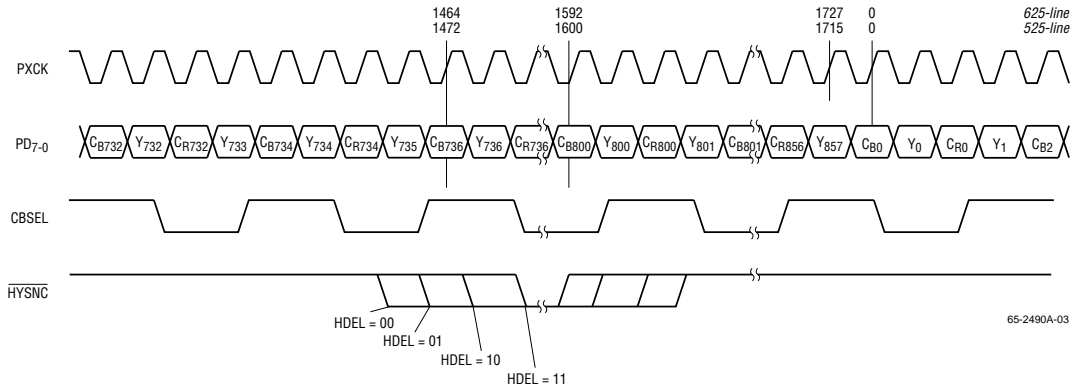

Figure 2a. HDEL Timing

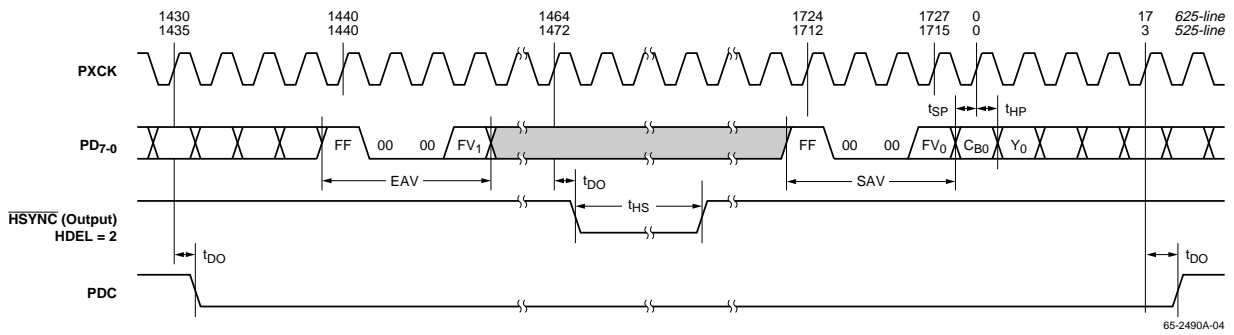

Figure 2b. CCIR-656 Horizontal Interval Timing Detail

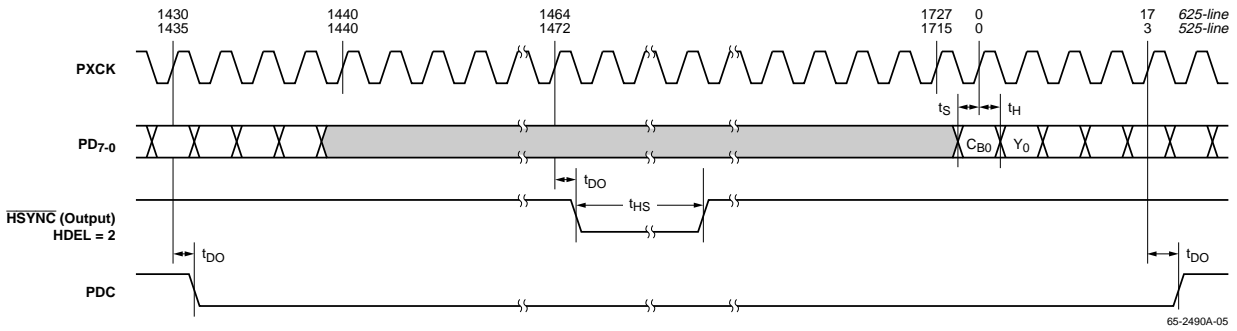

Figure 3. Master Mode Horizontal Interval Timing Detail

Horizontal and Vertical Timing

Horizontal and vertical video timing in the TMC2490(1)A is preprogrammed for line-locked systems with a 2x pixel clock of 27.0 MHz.

Table 3 and Table 4 show timing parameters for NTSC and PAL standards and the resulting TMC2490(1)A analog output timing. The user provides exactly 720 pixels of active video per line. In master mode, the TMC2490(1)A precisely controls the duration and activity of every segment of the horizontal line and vertical field group. In external sync slave mode, it holds the end-of-line blank state (e.g. front porch for active video lines) until it receives the next horizontal

sync signal. In CCIR-656 slave mode, it likewise holds each end-of-line blank state until it receives the next end of active video (EAV) signal embedded in the incoming data stream.

The vertical field group comprises several different line types based upon the Horizontal line time.

$$H = (2 \times SL) + (2 \times SH) \text{ [Vertical sync pulses]}$$

$$= (2 \times EL) + (2 \times EH) \text{ [Equalization pulses]}$$

SMPTE 170M NTSC and Report 624 PAL video standards call for specific rise and fall times on critical portions of the video waveform. The chip does this automatically, requiring no user intervention. The TMC2490(1)A digitally defines

slopes compatible with SMPTE 170M NTSC or CCIR Report 624 PAL on all vital edges:

1. Sync leading and trailing edges.
2. Burst envelope.

3. Active video leading and trailing edges.
4. All vertical interval equalization pulse and sync edges.

Table 3. Horizontal Timing Standards and Actual Values for 60 fps Video Standards (μs)

Parameter		NTSC (SMPTE 170M)			PAL-M (CCIR 624)			TMC2490(1)A
		Min	Nom	Max	Min	Nom	Max	
Front porch	FP	1.4	1.5	1.6	1.27		2.22	1.53
Horiz. Sync	SY	4.6	4.7	4.8	4.6	4.7	4.8	4.74
Breezeway	BR		0.608		0.9	1.1	1.3	0.59 (NTSC) 1.04 (PAL-M)
Color Burst	BU	2.235	2.514	2.794	2.237	2.517	2.797	2.31
Color Back porch	CBP		1.378		0.503		2.363	1.65 (NTSC) 0.89 (PAL-M)
Blanking	BL	10.5	10.7	11.0	10.7	10.9	11.1	10.8
Active Video	VA	52.56	52.86	53.06	52.46	52.66	52.86	52.633
Line Time	H		63.556			63.556		63.557
Equalization HIGH	EH		29.5			29.5		29.47
Equalization LOW	EL		2.3			2.3		2.31
Sync HIGH	SH		4.7			4.7		4.67
Sync LOW	SL		27.1			27.1		27.13
Sync rise and fall times			140±20ns			<250 ns		135ns

Table 4. Horizontal Timing Standards and Actual Values for 50 fps Video Standards (μs)

Parameter		PAL-B,G,H,I (CCIR 624)			PAL-N (CCIR 624)			TMC2490(1)A
		Min	Nom	Max	Min	Nom	Max	
Front porch	FP	1.2	1.5	1.8	1.2	1.5	1.8	1.57
Horiz. Sync	SY	4.5	4.7	4.9	4.5	4.7	4.9	4.74
Breezeway	BR	0.6	0.9	1.2	0.6	0.9	1.2	0.89
Color Burst	BU	2.030	2.255	2.481	2.233	2.513	2.792	2.3
Color Back porch	CBP		2.654			2.387		2.3
Blanking	BL	11.7	12.0	12.3	11.7	12.0	12.3	1.8
Active Video	VA	51.7	52.0	52.3	51.7	52.0	52.3	52.2
Line Time	H		64			64		64.0
Equalization HIGH	EH		29.65			29.65		29.63
Equalization LOW	EL		2.35			2.35		2.37
Sync HIGH	SH		4.7			4.7		4.67
Sync LOW	SL		27.3			27.3		27.3
Sync rise and fall times			250±50 ns			200±100 ns		250

Preliminary Information

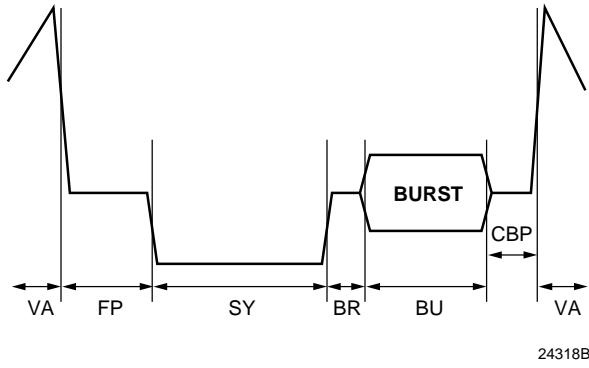

Figure 4. Horizontal Blanking Interval Timing

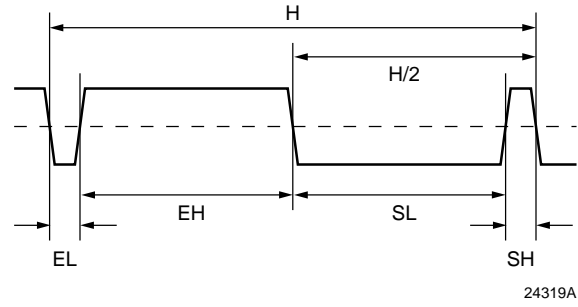

Figure 5. Vertical Sync and Equalization Pulse Detail

Preliminary Information

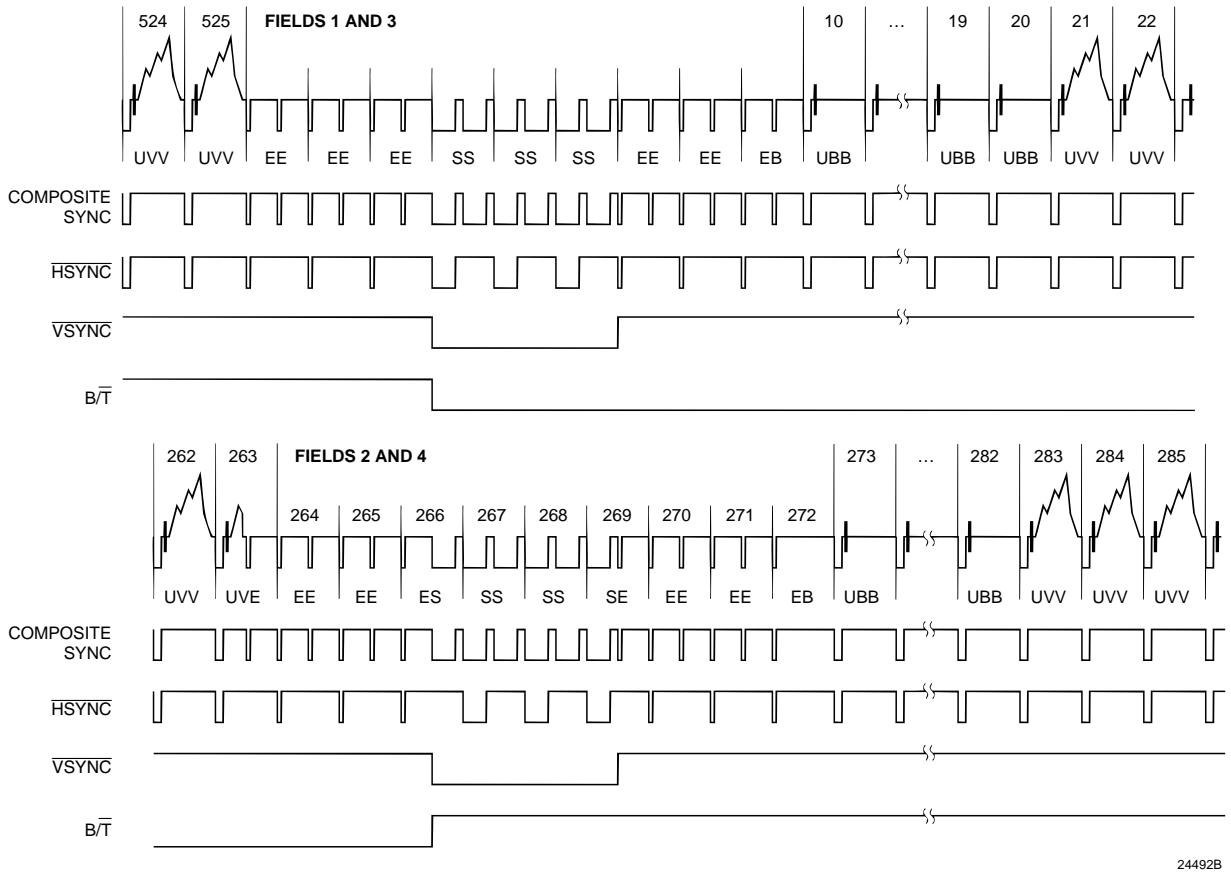

Figure 6. NTSC Vertical Interval

Table 6. NTSC Field/Line Sequence and Identification

Field 1, FID = 00		Field 2, FID = 01		Field 3, FID = 10		Field 4, FID = 11	
Line	ID	Line	ID	Line	ID	Line	ID
1	EE	264	EE	1	EE	264	EE
2	EE	265	EE	2	EE	265	EE
3	EE	266	ES	3	EE	266	ES
4	SS	267	SS	4	SS	267	SS
5	SS	268	SS	5	SS	268	SS
6	SS	269	SE	6	SS	269	SE
7	EE	270	EE	7	EE	270	EE
8	EE	271	EE	8	EE	271	EE
9	EE	272	EB	9	EE	272	EB
10	UBB	273	UBB	10	UBB	273	UBB
...
20	UBB	282	UBB	20	UBB	282	UBB
21	UVV	283	UVV	10	UVV	273	UVV
...
262	UVV	524	UVV	262	UVV	524	UVV
263	UVE	525	UVV	263	UVE	525	UVV

EE Equalization pulse

SE Half-line vertical sync pulse, half-line equalization pulse

SS Vertical sync pulse

ES Half-line equalization pulse, half-line vertical sync pulse

EB Equalization broad pulse

UBB Black and Burst¹

UVV Active video

UVE Half-line video, half-line equalization pulse

Note:

1. VBB lines are changed to UVV (Active Video) when VBIEN = 1.

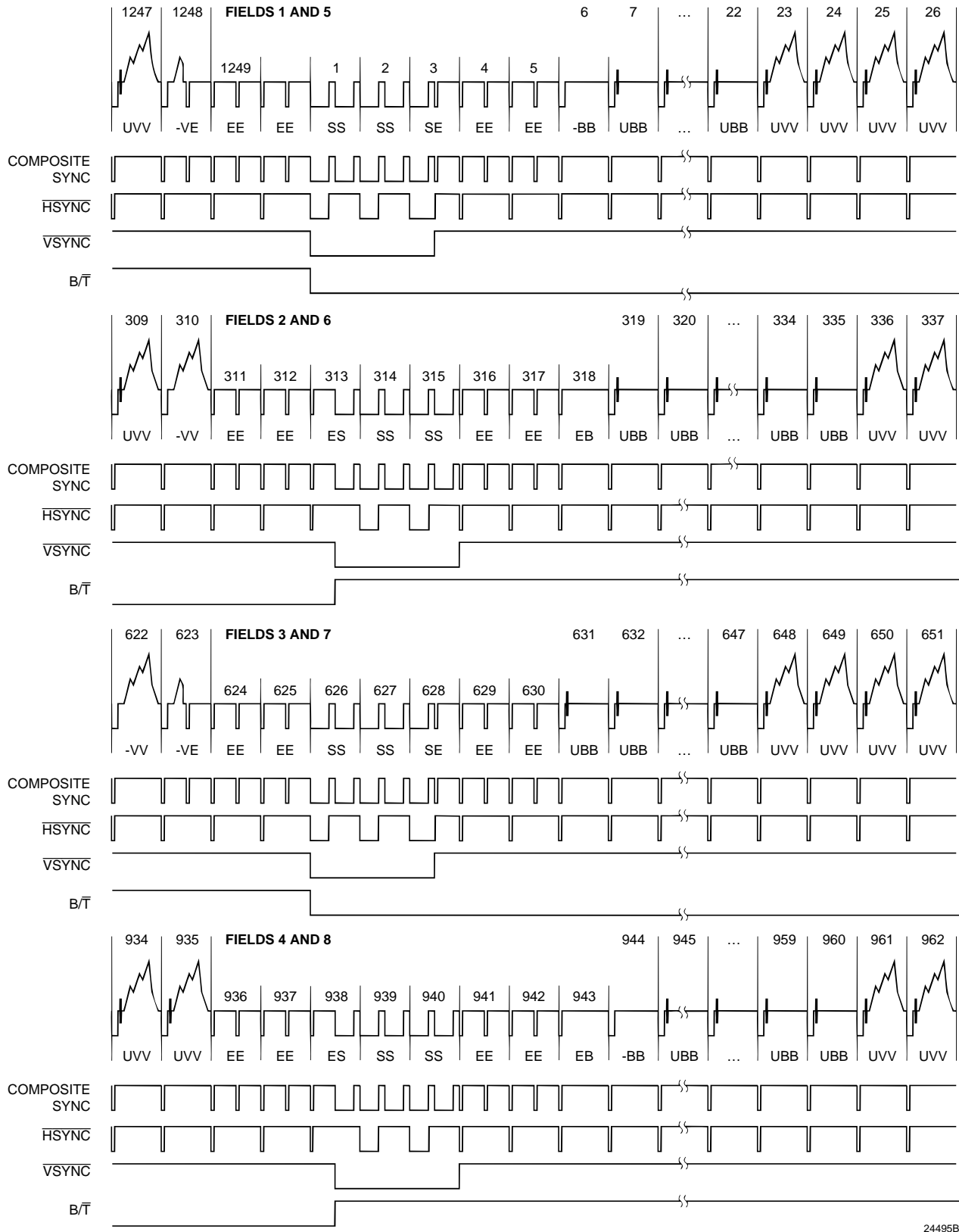

24495B

Figure 7. PAL-B,G,H,I,N Vertical Interval

Table 7. PAL-B,G,H,I,N Field/Line Sequence and Identification

Fields 1 and 5 FID = 000, 100		Fields 2 and 6 FID = 001, 101		Fields 3 and 7 FID = 010, 110		Fields 4 and 8 FID = 011, 111	
Line	ID	Line	ID	Line	ID	Line	ID
1	SS	313	ES	626	SS	938	ES
2	SS	314	SS	627	SS	939	SS
3	SE	315	SS	628	SE	940	SS
4	EE	316	EE	629	EE	941	EE
5	EE	317	EE	630	EE	942	EE
6	-BB	318	EV	631	UBB	943	EB
7	UBB	319	UBB	632	UBB	944	-BB
8	UBB	320	UBB	633	UBB	945	UBB
...
22	UBB	335	UBB	647	UBB	960	UBB
23	UVV	336	UVV	648	UVV	961	UVV
...
308	UVV	621	UVV	933	UVV	1246	UVV
309	UVV	622	-VV	934	UVV	1247	UVV
310	-VV	623	-VE	935	UVV	1248	-VE
311	EE	624	EE	936	EE	1249	EE
312	EE	625	EE	937	EE	1250	EE

EE Equalization pulse

SE Half-line vertical sync pulse, half-line equalization pulse

SS Vertical sync pulse

ES Half-line equalization pulse, half-line vertical sync pulse

EB Equalization broad pulse

UBB Black and Burst¹

UVV Active video

-BB Blank line with color burst suppression²

-VV Active video with color burst suppressed

-VE Half-line video, half-line equalization pulse, color burst suppressed

Notes:

1. VBB lines are changed to UVV (Active Video) when VBIEN = 1.

2. -BB lines are changed to -VV (Active Video, Burst Suppressed) when VBIEN = 1.

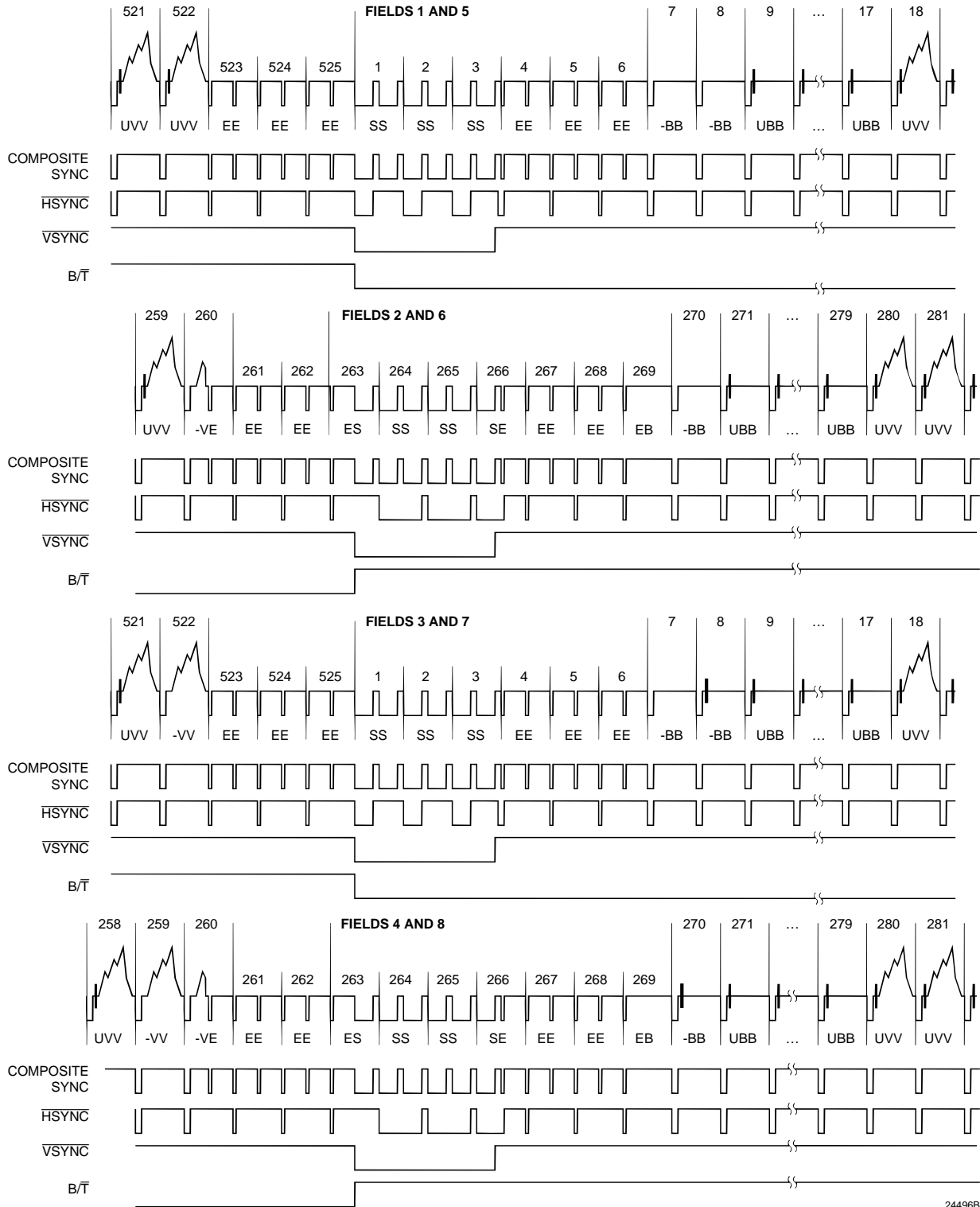

24496B

Figure 8. PAL-M Vertical Interval

Table 8. PAL-M Field/Line Sequence and Identification

Field 1 and 5 FID = 000, 100		Field 2 and 6 FID = 001, 101		Field 3 and 7 FID = 010, 110		Field 4 and 8 FID = 011, 111	
Line	ID	Line	ID	Line	ID	Line	ID
1	SS	263	ES	1	SS	263	ES
2	SS	264	SS	2	SS	264	SS
3	SS	265	SS	3	SS	265	SS
4	EE	266	SE	4	EE	266	SE
5	EE	267	EE	5	EE	267	EE
6	EE	268	EE	6	EE	268	EE
7	-BB	269	EB	7	-BB	269	EB
8	-BB	270	-BB	8	UBB	270	-BB
9	UBB	271	UBB	9	UBB	271	UBB
...
17	UBB	279	UBB	17	UBB	279	UBB
18	UVV	280	UVV	18	UVV	280	UVV
...
258	UVV	521	UVV	258	UVV	521	UVV
259	UVV	522	-VV	259	-VV	522	UVV
260	-VE	523	EE	260	-VE	523	EE
261	EE	524	EE	261	EE	524	EE
262	EE	525	EE	262	EE	525	EE

EE Equalization pulse

SE Half-line vertical sync pulse, half-line equalization pulse

SS Vertical sync pulse

ES Half-line equalization pulse, half-line vertical sync pulse

EB Equalization broad pulse

-VE Half-line video, half-line equalization pulse, color burst suppressed

UBB Black and Burst¹

UVV Active video

-BB Blank line with color burst suppression²

-VV Active video with color burst suppressed

UVV Half-line black, half-line video

Notes:

1. VBB lines are changed to UVV (Active Video) when VBIEN = 1
2. -BB lines are changed to -VV (Active Video, Burst Suppressed) when VBIEN = 1

Subcarrier Generation and Synchronization

The color subcarrier is generated by an internal digital frequency synthesizer. The subcarrier synthesizer gets its frequency and phase values preprogrammed into the TMC2490(1)A.

In Master Mode, the subcarrier is internally synchronized on field 1 of the eight-field sequence to establish and maintain a specific relationship between the leading edge of horizontal sync and color burst phase (SCH). Proper subcarrier phase is maintained through the entire eight field set, including the 25 Hz offset in PAL-N/B/I systems. The subcarrier is reset to the phase values found in Table 9.

SCH Phase Control

SCH refers to the timing relationship between the 50% point of the leading edge of horizontal sync and the first positive or negative zero-crossing of the color burst subcarrier reference. In PAL, SCH is defined for line 1 of field 1, but since there is no color burst on line 1, SCH is usually measured at line 7 of field 1. The need to specify SCH relative to a particular line in PAL is due to the 25 Hz offset of PAL subcarrier frequency. Since NTSC has no such 25 Hz offset, SCH applies to all lines.

Preliminary Information

Table 9. Subcarrier and Color Burst Reset Values

	NTSC	PAL-M	PAL-B,G,H,I,N
Digital field:	1	1	1
Line number:	4	4	1
Subcarrier phase reset value:	180°	0°	0°
Resultant color burst phase:	0°	+135°	+135°

Note:

- Line numbering is in accordance with Figure 6, Figure 7, and Figure 8. Subcarrier and color burst phase are relative to the horizontal reference of the line specified above.

Table 10. Standard Subcarrier Parameters

Standard	Horizontal Frequency (KHz)	Subcarrier Frequency (MHz)
NTSC	15.734266	3.579545455
PAL B,G,H,I	15.625000	4.43361875
PAL-M	15.734266	3.57561189
PAL-N	15.625000	3.58205625

Table 11. Luminance Input Codes

PD7-0 Input		Luma Level (CCIR-601)	NTSC, PAL-M Luma Level (IRE)		PAL-B,G,H,I,N Luma Level (mV)
Dec	Hex		PEDEN = 0	PEDEN = 1	
255	FF	Reserved	0	7.5	0
254	FE		108.7	108	761
235	EB	100% white	100	100	700
16	10	Black	0	7.5	0
1	01		-6.9	1.2	-48
0	00	Reserved	0	7.5	0

Table 12. D/A Converter and Analog Levels

Video Level	NTSC, PAL-M		NTSC w/o Setup		PAL-B,G,H,I,N	
	D/A	IRE	D/A	IRE	D/A	mV
Maximum Output	1022	134.8	1022	138.4	1022	817
100% white	820	100	820	100	800	700
Black	284	7.5	240	0	240	0
Blank	240	0	240	0	240	0
Sync	12	-40	12	-40	0	-300
White-to-blank	580	100	580	100	560	700
White-to- sync	808	140	808	140	800	1000
Color burst p-p	232	40	232	40	244	300

Luminance Processing

During horizontal and vertical blanking, the luma processor generates blanking levels and properly timed and shaped sync and equalization pulses. During active video, it captures and rescales the incoming Y components and adds the results to the blank level to complete a proper monochrome television waveform, which is then upsampled to drive the luma D/A and the composite adder.

For NTSC-EIA (5:2 white:sync, no black pedestal), the overall luma input-to-output equation for $0 < Y < 255$ is:

$$\text{luma out (IRE, relative to blank)} = (Y - 16) * 100/219$$

For NTSC and PAL-M (5:2, with 7.5 IRE pedestal), the equation becomes:

$$\text{luma out (IRE, relative to blank)} = (Y - 16) * 92.5/219 + 7.5$$

For all 625-line PAL standards (7:3, no pedestal), the equation becomes:

$$\text{luma out (mV, relative to blank)} = (Y-16) * 700/219$$

Since $Y=0$ and $Y=255$ are reserved values in CCIR-601, results in the luma D/A outputting black, i.e., 0mV or 0 IRE without pedestal, 7.5 IRE with pedestal. External components are needed to bias the blanking/black level to 0mV/0 IRE. The values given in Table 11 and Table 12 reflect a biased output where the blanking level is at 0mV/0 IRE.

Filtering Within the TMC2490(1)A

The TMC2490(1)A incorporates internal digital filters to establish appropriate bandwidths and simplify external analog reconstruction filter designs.

The chroma portion of the incoming digital video is band-limited to reduce edge effect and other distortions of the image compression process. Chrominance bandwidth is selected by CHRBW. When LOW, the chrominance passband attenuation is <3 dB within ± 650 kHz from f_{SC} . The stopband rejection is >26 dB outside $f_{SC} \pm 2$ MHz. When HIGH, the chrominance passband attenuation is <3 dB within ± 1.3 MHz from f_{SC} . The stopband rejection is >33 dB outside $f_{SC} \pm 4$ MHz.

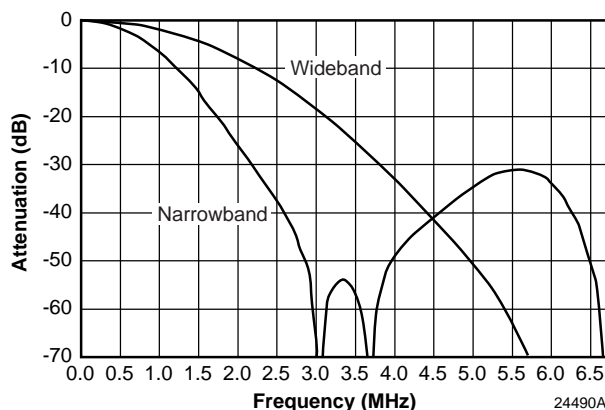

Figure 9. Color-Difference Low-Pass Filter Response

The Chroma Modulator output and the luminance data are digitally filtered with sharp-cutoff low-pass interpolation filters. These filters ensure that aliased subcarrier, chrominance, and luminance frequencies are sufficiently suppressed above the video base-band.

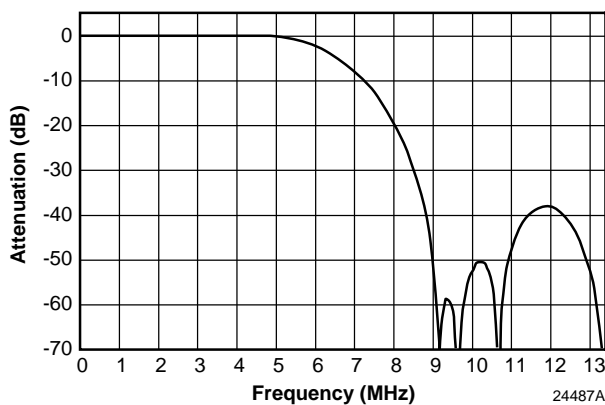

Figure 10. Chrominance and Luminance Interpolation Filter – Full Spectrum Response

Virtually all digital-to-analog converters have a response with high frequency roll-off as a result of the zero-order hold characteristic of classic D/A converters. This response is commonly referred to as a $\sin(x)/x$ response. The $\sin(x)/x$ vs. sampling frequency is shown in Figure 12.

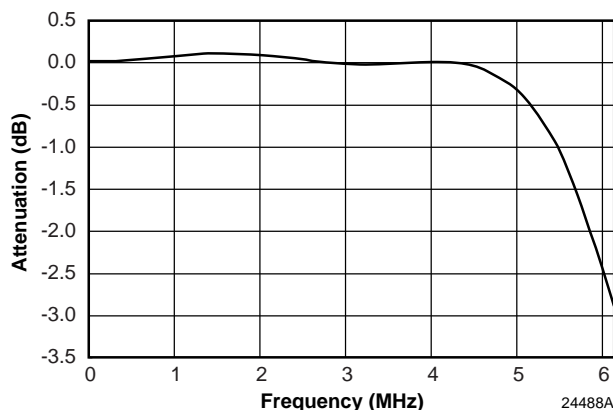

Figure 11. Chrominance and Luminance Interpolation Filter – Passband Detail

The TMC2490(1)A's digital interpolation filters convert the data stream to a sample rate of twice the pixel rate. This results in much less high frequency $\sin(x)/x$ rolloff and the output spectrum between $f_s/4$ and $3 \times f_s/4$ contains very little energy. Since there is so little signal energy in this frequency band, the demands placed on the output reconstruction filter are greatly reduced. The output filter needs to be flat to $f_s/4$ and have good rejection at $3 \times f_s/4$. The relaxed requirements greatly simplify the design of a filter with good phase response and low group delay distortion. A small amount of peaking may be added to compensate residual $\sin(x)/x$ rolloff.

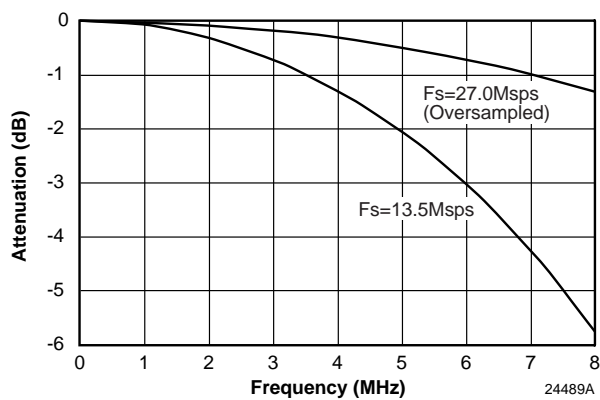

Figure 12. $\sin(x)/x$ Response

Closed Caption Insertion

The TMC2490(1)A includes a flexible closed caption processor. It may be programmed to insert a closed caption signal on any line within a range of 16 lines on ODD and/or EVEN fields.

Closed Caption insertion overrides all other configurations of the encoder. If it is specified on an active video line, it takes precedence over the video data and removes NTSC setup if setup has been programmed for the active video lines.

Closed Caption Control

Closed caption is turned on by setting CCON HIGH. Whenever the encoder begins producing a line specified by CCFLD and CCLINE, it will insert a closed caption line in its place. If CCRTS is HIGH, the data contained in CCDx will be sent. If CCRTS is LOW, Null Bytes (hex 00 with ODD parity) will be sent.

Line Selection

The line to contain CC data is selected by a combination of the CCFLD bit and the CCLINE bits. CCLINE is added to the offset shown in Table 13 to specify the line.

Table 13. Closed Caption Line Selection

Standard	Offset	Field	Lines
525	12	ODD	12-27
	274	EVEN	274-289
625	9	ODD	9-24
	321	EVEN	321-336

Parity Generation

Standard Closed-Caption signals employ ODD parity, which may be automatically generated by setting CCPAR HIGH. Alternatively, parity may be generated externally as part of the bytes to be transmitted, and, with CCPAR LOW, the entire 16 bits loaded into the CCDx registers will be sent unchanged.

Operating Sequence

A typical operational sequence for closed-caption insertion on Line 21 is:

1. Read Register 22 and check that bit 6 is LOW, indicating that the CCDx registers are ready to accept data.
2. If ready, write two bytes of CC data into registers 20 and 21.

3. Write into register 22 the proper combination of CCFLD and CCLINE. CCPAR may be written as desired. Set CCRTS HIGH.
4. The CC data is transmitted during the specified line.

As soon as CCDx is transferred into the CC processor (and CCRTS goes LOW), new data may be loaded into registers 20 and 21. This allows the user to transmit CC data on several consecutive lines by loading data for line n+1 while data is being sent on line n.

Registers 20-21 auto-increment when read or written. Register 22 does not. The microcontroller can repeatedly read register 22 until CCRTS is found to be LOW, then address register 20 and write three auto-incremented bytes to set up for the next CC line.

Parallel Microprocessor Interface

The parallel microprocessor interface, active when \overline{SER} is HIGH, employs an 11-line interface, with an 8-bit data bus and one address bit: two addresses are required for device programming and pointer-register management. Address bit 0 selects between reading/writing the register addresses and reading/writing register data. When writing, the address is presented along with a LOW on the R/\overline{W} pin during the falling edge of \overline{CS} . Eight bits of data are presented on D7-0 during the subsequent rising edge of \overline{CS} .

In read mode, the address is accompanied by a HIGH on the R/\overline{W} pin during a falling edge of \overline{CS} . The data output pins go to a low-impedance state t_{DOZ} ns after \overline{CS} falls. Valid data is present on D7-0 t_{DOM} after the falling edge of \overline{CS} .

Table 14. Parallel Port Control

ADR	R/\overline{W}	Action
1	0	Load D7-0 into Control Register pointer.
1	1	Read Control Register pointer on D7-0.
0	0	Write D7-0 to addressed Control Register.
0	1	Read addressed Control Register on D7-0.

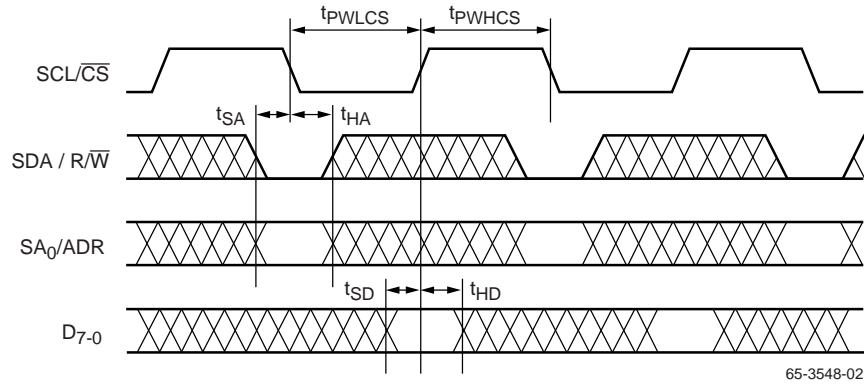

Figure 13. Microprocessor Parallel Port - Write Timing

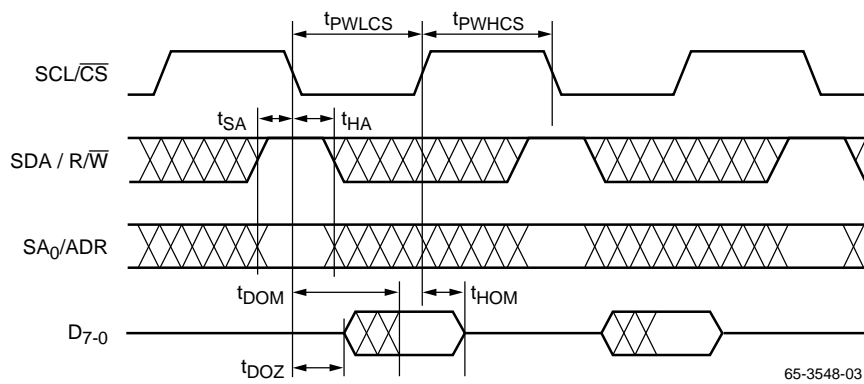

Figure 14. Microprocessor Parallel Port - Read Timing

Serial Control Port (R-Bus)

In addition to the 11-wire parallel port, a 2-wire serial control interface is also provided, and active when SER is LOW. Either port alone can control the entire chip. Up to four TMC2490(1)A devices may be connected to the 2-wire serial interface with each device having a unique address.

The 2-wire interface comprises a clock (SCL/CS) and a bi-directional data (SDA/R/W) pin. The TMC2490(1)A acts as a slave for receiving and transmitting data over the serial interface. When the serial interface is not active, the logic levels on SCL/CS and SDA/R/W are pulled HIGH by external pull-up resistors.

Data received or transmitted on the SDA/R/W line must be stable for the duration of the positive-going SCL/CS pulse. Data on SDA/R/W can only change when SCL/CS is LOW. If SDA/R/W changes state while SCL/CS is HIGH, the serial interface interprets that action as a start or stop sequence.

There are five components to serial bus operation:

- Start signal
- Slave address byte

- Base register address byte
- Data byte to read or write
- Stop signal

When the serial interface is inactive (SCL/CS and SDA/R/W are HIGH) communications are initiated by sending a start signal. The start signal is a HIGH-to-LOW transition on SDA/R/W while SCL/CS is HIGH. This signal alerts all slaved devices that a data transfer sequence is coming.

The first eight bits of data transferred after a start signal comprise a seven bit slave address and a single R/W bit. As shown in Figure 16A, the R/W bit indicates the direction of data transfer, read from or write to the slave device. If the transmitted slave address matches the address of the device (set by the state of the SA0/ADR and SA1 input pins in Table 15), the TMC2490(1)A acknowledges by bringing SDA/R/W LOW on the 9th SCL/CS pulse. If the addresses do not match, the TMC2490(1)A does not acknowledge.

Table 15. Serial Port Addresses

A6	A5	A4	A3	A2	A1 (SA1)	A0 (SA0)
0	0	0	1	1	0	0
0	0	0	1	1	0	1
0	0	0	1	1	1	0
0	0	0	1	1	1	1

Data Transfer via Serial Interface

For each byte of data read or written, the MSB is the first bit of the sequence.

If the TMC2490(1)A does not acknowledge the master device during a write sequence, the SDA/R \bar{W} remains HIGH so the master can generate a stop signal. If the master device does not acknowledge the TMC2490(1)A during a read sequence, the TMC2490(1)A interprets this as “end of data.” The SDA/R \bar{W} remains HIGH so the master can generate a stop signal.

Writing data to specific control registers of the TMC2490(1)A requires that the 8-bit address of the control register of interest be written after the slave address has been established. This control register address is the base address for subsequent write operations. The base address auto-increments by one for each byte of data written after the data

byte intended for the base address. If more bytes are transferred than there are available addresses, the address will not increment and will remain at its maximum value of 22h. Any base address higher than 22h will not produce an ACKnowledge signal.

Data is read from the control registers of the TMC2490(1)A in a similar manner. Reading requires two data transfer operations:

- The base address must be written with the R \bar{W} bit of the slave address byte LOW to set up a sequential read operation.
- Reading (the R \bar{W} bit of the slave address byte HIGH) begins at the previously established base address. The address of the read register auto-increments after each byte is transferred.

To terminate a read/write sequence to the TMC2490(1)A, a stop signal must be sent. A stop signal comprises of a LOW-to-HIGH transition of SDA/R \bar{W} while SCL/ \bar{CS} is HIGH.

A repeated start signal occurs when the master device driving the serial interface generates a start signal without first generating a stop signal to terminate the current communication. This is used to change the mode of communication (read, write) between the slave and master without releasing the serial interface lines.

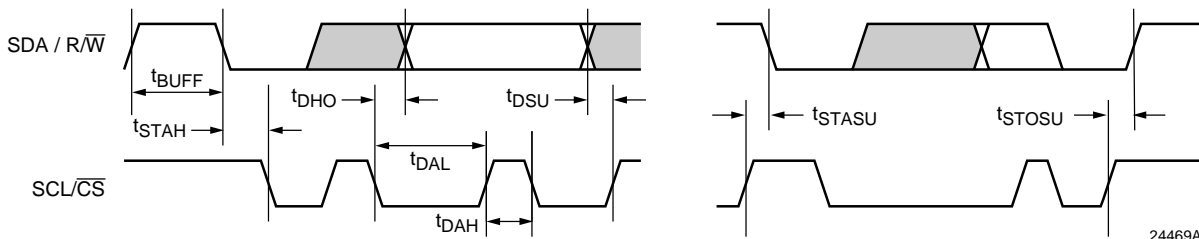

Figure 15. Serial Port Read/Write Timing

24469A

Serial Interface Read/Write Examples

Write to one control register

- Start signal
- Slave Address byte (R/W bit = LOW)
- Base Address byte
- Data byte to base address
- Stop signal

Write to four consecutive control registers

- Start signal
- Slave Address byte (R/W bit = LOW)
- Base Address byte
- Data byte to base address
- Data byte to (base address + 1)
- Data byte to (base address + 2)
- Data byte to (base address + 3)
- Stop signal

Read from one control register

- Start signal
- Slave Address byte (R/W bit = LOW)
- Base Address byte
- Stop signal
- Start signal
- Slave Address byte (R/W bit = HIGH)
- Data byte from base address
- No Acknowledge

Read from four consecutive control registers

- Start signal
- Slave Address byte (R/W bit = LOW)
- Base Address byte
- Stop signal
- Start signal
- Slave Address byte (R/W bit = HIGH)
- Data byte from base address
- Data byte from (base address + 1)
- Data byte from (base address + 2)
- Data byte from (base address + 3)
- No Acknowledge

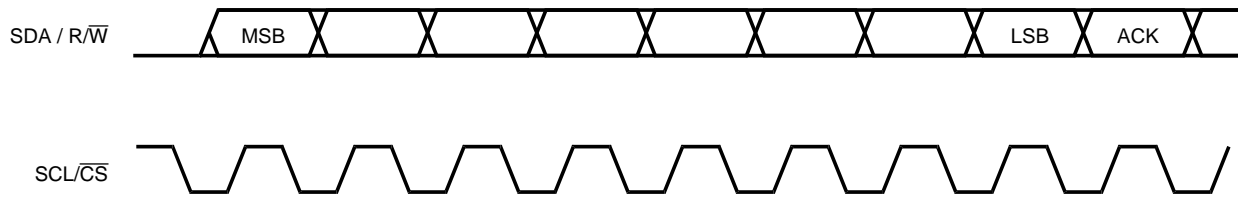

Figure 16. Serial Interface – Typical Byte Transfer

24470A

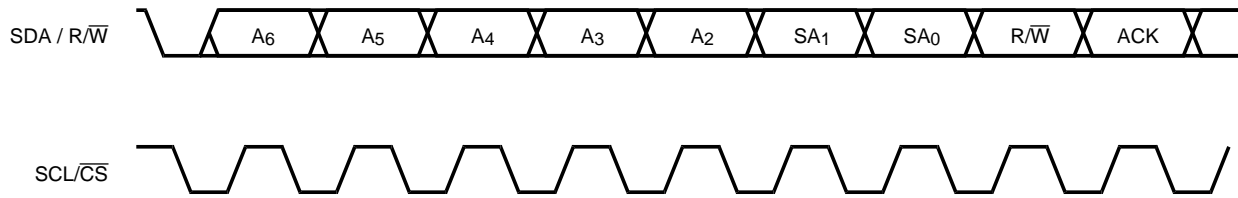

Figure 16A. Chip Address with Read/Write Bit

65-3648-05

Equivalent Circuits and Threshold Levels

Preliminary Information

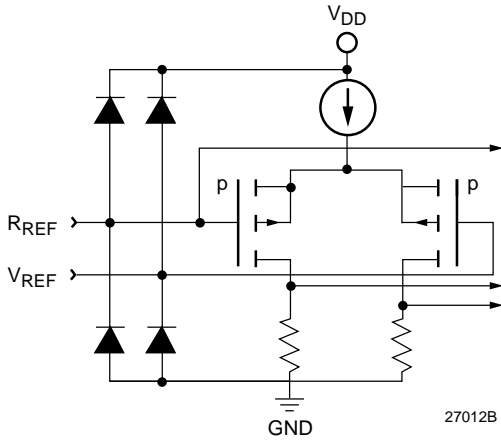

Figure 18. Equivalent Analog Input Circuit

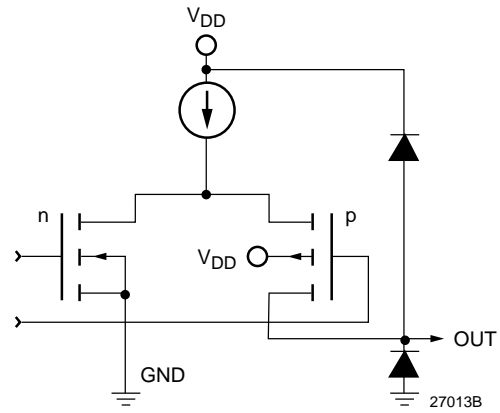

Figure 19. Equivalent Analog Output Circuit

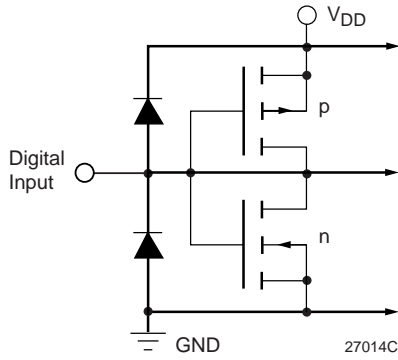

Figure 20. Equivalent Digital Input Circuit

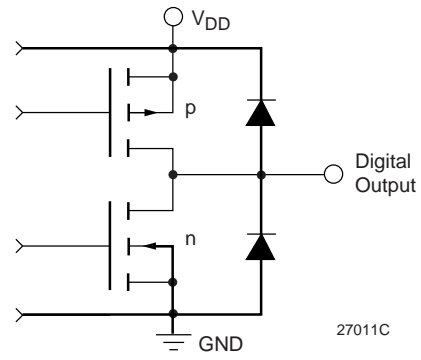

Figure 21. Equivalent Digital Output Circuit

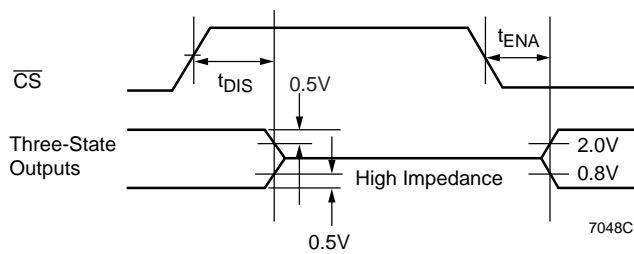

Figure 22. Threshold Levels for Three-State Measurements

Absolute Maximum Ratings

(beyond which the device may be damaged)¹

Parameter	Min.	Typ.	Max.	Unit
Power Supply Voltage	-0.5		7.0	V
Digital Inputs				
Applied Voltage ²	-0.5		V _{DD} + 0.5	V
Forced Current ^{3,4}	-20.0		20.0	mA
Output				
Applied Voltage ²	-0.5		V _{DD} + 0.5	V
Forced Current ^{3,4}	-3.0		6.0	mA
Short Circuit Duration (single output in HIGH state to ground)			1	sec
Analog Short Circuit Duration (all outputs to ground)	Infinite			
Temperature				
Operating, Ambient	-20		110	°C
Junction			140	°C
Storage Temperature	-65		150	°C
Lead Soldering (10 seconds)			300	°C
Vapor Phase Soldering (1 minute)			220	°C

Notes:

- Functional operation under any of these conditions is NOT implied. Performance and reliability are guaranteed only if Operating Conditions are not exceeded.
- Applied voltage must be current limited to specified range.
- Forcing voltage must be limited to specified range.
- Current is specified as conventional current flowing into the device.

Operating Conditions

Parameter	Conditions	Min.	Typ.	Max.	Units
V _{DD}	Power Supply Voltage	4.75	5.0	5.25	V
V _{IH}	Input Voltage, Logic HIGH	TTL Compatible Inputs	2.0	V _{DD}	V
		CLK Input	2.4	V _{DD}	
		R-Bus Inputs	0.7V _{DD}		
V _{IL}	Input Voltage, Logic LOW	TTL Compatible Inputs	GND	0.8	V
		R-Bus Inputs		0.3V _{DD}	
V _{REF}	External Reference Voltage		1.235		V
I _{REF}	D/A Converter Reference Current	(I _{REF} = V _{REF} /R _{REF}), flowing out of the R _{REF} pin		1.57	mA
R _{REF}	External Reference Resistor	V _{REF} = NOM		787	Ω
I _{OH}	Output Current, Logic HIGH			-2.0	mA
I _{OL}	Output Current, Logic LOW			4.0	mA
T _A	Ambient Temperature, Still Air	0		70	°C

Operating Conditions (continued)

Parameter		Conditions	Min.	Typ.	Max.	Units
Pixel Interface						
fPXL	Pixel Rate			13.5		Mpps
fPXCK	Master Clock Rate	= 2X pixel rate		27.0		MHz
tPWHPX	PXCK pulse width, HIGH		10			ns
tPWLPX	PXCK pulse width, LOW		15			ns
tSP	PD7-0 Setup Time		15			ns
tHP	PD7-0 Hold Time		0			ns
Parallel Microprocessor Interface						
tPWLCS	$\overline{\text{CS}}$ Pulse Width, LOW		95			ns
tPWHCS	$\overline{\text{CS}}$ Pulse Width, HIGH		3			pixels
tSA	Address Setup Time		17			ns
tHA	Address Hold Time		0			ns
tSD	Data Setup Time (write)		17			ns
tHD	Data Hold Time (write)		0			ns
tPWLR	RESET Pulse Width, LOW		16			PXCK
Serial Microprocessor Interface						
tDAL	SCL Pulse Width, LOW			1.3		μs
tDAH	SCL Pulse Width, HIGH			0.6		μs
tSTAH	SDA Start Hold Time			0.6		μs
tSTASU	SCL to SDA Setup Time (Stop)			0.6		μs
tSTOSU	SCL to SDA Setup Time (Start)			0.6		μs
tBUFF	SDA Stop Hold Time Setup			1.3		μs
tDSU	SDA to SCL Data Setup Time			300		ns
tDHO	SDA to SCL Data Hold Time			300		ns

DC Electrical Characteristics

Parameter		Conditions	Min.	Typ.	Max.	Units
I _{DD}	Power Supply Current, Unloaded ¹	V _{DD} = Max, f _{PXCK} = 27MHz			130	mA
I _{DDQ}	Power Supply Current, Quiescent ²	V _{DD} = Max			20	mA
V _{RO}	Voltage Reference Output		1.173	1.235	1.297	V
I _{BR}	Reference Bias		-100			μA
Z _{RO}	VREF Output Impedance			1000		Ω
I _{IH}	Input Current, HIGH	V _{DD} = Max, V _{IN} = V _{DD}			±10	μA
I _{IL}	Input Current, LOW	V _{DD} = Max, V _{IN} = 0V			±10	μA
I _{OZH}	Hi-Z Output Leakage Current, Output HIGH	V _{DD} = Max, V _{IN} = V _{DD}			±10	μA
I _{OZL}	Hi-Z Output Leakage Current, Output LOW	V _{DD} = Max, V _{IN} = 0V			±10	μA
I _{OS}	Short-Circuit Current		-50		-10	mA
V _{OH}	Output Voltage, HIGH	I _{OH} = Max	2.4			V
V _{OL}	Output Voltage, LOW	I _{OL} = Max			0.4	V
C _I	Digital Input Capacitance			4	10	pF
C _O	Digital Output Capacitance			10		pF
V _{OC}	Video Output Compliance		-0.3		2.0	V
R _{OUT}	Video Output Resistance			15		kΩ
C _{OUT}	Video Output Capacitance	I _{OUT} = 0mA, f = 1MHz		15	25	pF

Notes:

1. Maximum I_{DD} with V_{DD} = Max and T_A = Min. Outputs loaded with 75Ω.
2. I_{DDQ} when RESET = LOW, disabling D/A converters.

AC Electrical Characteristics

Parameter		Conditions	Min.	Typ.	Max.	Units
t _{DOZ}	Output Delay, \overline{CS} to low-Z		14			ns
t _{HOM}	Output Hold Time, \overline{CS} to high-Z		30			ns
t _{DOM}	Output Delay, \overline{CS} to Data Valid		30			ns
t _R	D/A Output Current Risetime	10% to 90% of full scale		2		ns
t _F	D/A Output Current Falltime	90% to 10% of full scale		2		ns
t _{DOV}	Analog Output Delay		3	11	17	ns

Note:

1. Timing reference points are at the 50% level. Analog C_{LOAD} <10pF, D7-0 load <40pF.

System Performance Characteristics

Parameter		Conditions	Min.	Typ.	Max.	Units
RES	D/A Converter Resolution		10	10	10	Bits
dp	Differential Phase	PXCK = 27 MHz, 40 IRE Ramp		0.6		degree
dg	Differential Gain	PXCK = 27 MHz, 40 IRE Ramp		0.7		%
CNLP	Chroma Nonlinear Phase	NTC-7 Combination		0.3		degree
CNLG	Chroma Nonlinear Gain	NTC-7 Combination		TBD		%
CLIM	Chroma/Luma Intermodulation	NTC-7 Combination		0.3		IRE
CLGI	Chroma/Luma Gain inequality	NTC-7 Composite		TBD		%
CLDI	Chroma/Luma Delay inequality	NTC-7 Composite		7.1		ns
LNLD	Luma Nonlinear Distortion	NTC-7		TBD		%
FTWD	Field Time Waveform Distortion	NTC-7		0.1		%
LTWD	Line Time Waveform Distortion	NTC-7		0.3		%
NOISE	Noise Level ¹	100% unmod. ramp		-55		dB rms
CAMN	Chroma AM Noise	Red field		-63		dB rms
CPMN	Chroma PM Noise	Red field		-62		dB rms
SYR	Sync Pulse Rise Time	NTSC		140		ns
		PAL		250		
SYF	Sync Pulse Fall Time	NTSC		140		ns
		PAL		250		
PSRR	Power Supply Rejection Ratio	CBYP = 0.1 μ F, f = 1 kHz		0.02		%/%VDD

Note:

1. Noise Level is uniformly weighted, 10 kHz to 5.0 MHz bandwidth, with Tilt Null ON measured using VM700 "Measure Mode."

Applications Information

The circuit in Figure 24 shows the connection of power supply voltages, output reconstruction filters and the external voltage reference. All VDD pins should be connected to the same power source.

The full-scale output voltage level, V_{OUT} , on the COMPOSITE, LUMA, and CHROMA pins is found from:

$$V_{OUT} = I_{OUT} \times R_L = K \times I_{REF} \times R_L$$

$$= K \times (V_{REF}/R_{REF}) \times R_L$$

where:

- I_{OUT} is the full-scale output current sourced by the TMC2490(1)A D/A converters.
- R_L is the net resistive load on the COMPOSITE, CHROMA, and LUMA output pins.
- K is a constant for the TMC2490(1)A D/A converters (approximately equal to 10.4).
- I_{REF} is the reference current flowing out of the RREF pin to ground.
- V_{REF} is the voltage measured on the VREF pin.
- R_{REF} is the total resistance connected between the RREF pin and ground.
- A 0.1µF capacitor should be connected between the CBYP pin and the adjacent VDDA, pin.

The reference voltage in Figure 24 is from an LM185 1.2 Volt band-gap reference. The 392 Ohm resistor connected from RREF to ground sets the overall "gain" of the three D/A converters of the TMC2490(1)A. A 787Ω resistor is used for single 75Ω termination. Varying $R_{REF} \pm 5\%$ will cause the full-scale output voltage on COMPOSITE, LUMA, and CHROMA to vary by $\pm 5\%$.

The suggested output reconstruction filter is the same one used on the TMC2063P7C Demonstration Board. The phase and frequency response of this filter is shown in Figure 23. The Schottky diode is for ESD protection.

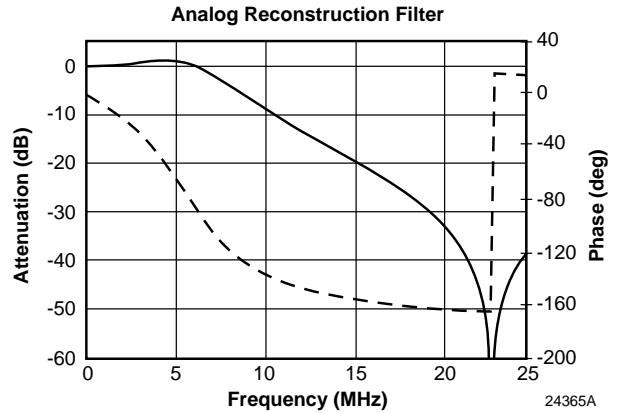

Figure 23. Response of Recommended Output Filter

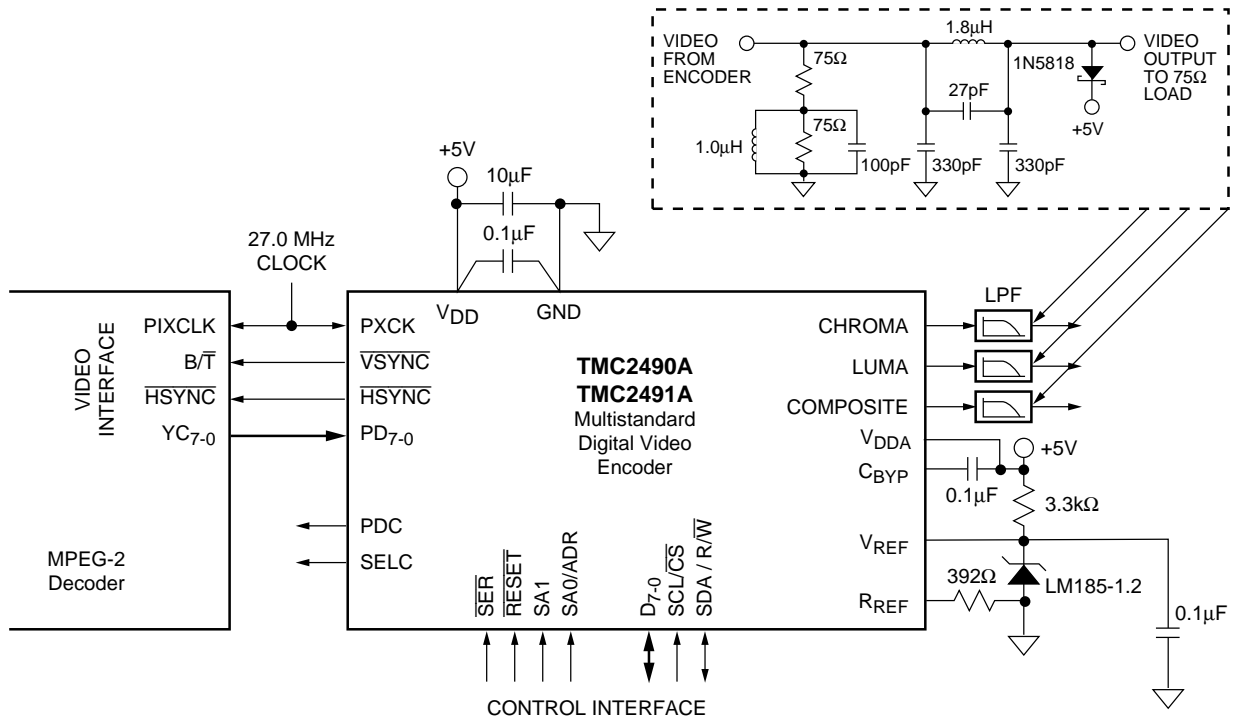

Figure 24. Typical Application Circuit

Preliminary Information

65-2490(1)A-03

Notes:

Preliminary Information

Notes:

Preliminary Information

Notes:

Preliminary Information

Mechanical Dimensions – 44-Pin PLCC Package

Symbol	Inches		Millimeters		Notes
	Min.	Max.	Min.	Max.	
A	.165	.180	4.20	4.57	
A1	.090	.120	2.29	3.04	
A2	.020	—	.51	—	
B	.013	.021	.33	.53	
B1	.026	.032	.66	.81	
D/E	.685	.695	17.40	17.65	
D1/E1	.650	.656	16.51	16.66	3
D3/E3	.500 BSC		12.7 BSC		
e	.050 BSC		1.27 BSC		
J	.042	.056	1.07	1.42	2
ND/NE	11		11		
N	44		44		
ccc	—	.004	—	0.10	

Notes:

1. All dimensions and tolerances conform to ANSI Y14.5M-1982
2. Corner and edge chamfer (J) = 45°
3. Dimension D1 and E1 do not include mold protrusion. Allowable protrusion is .101" (.25mm)

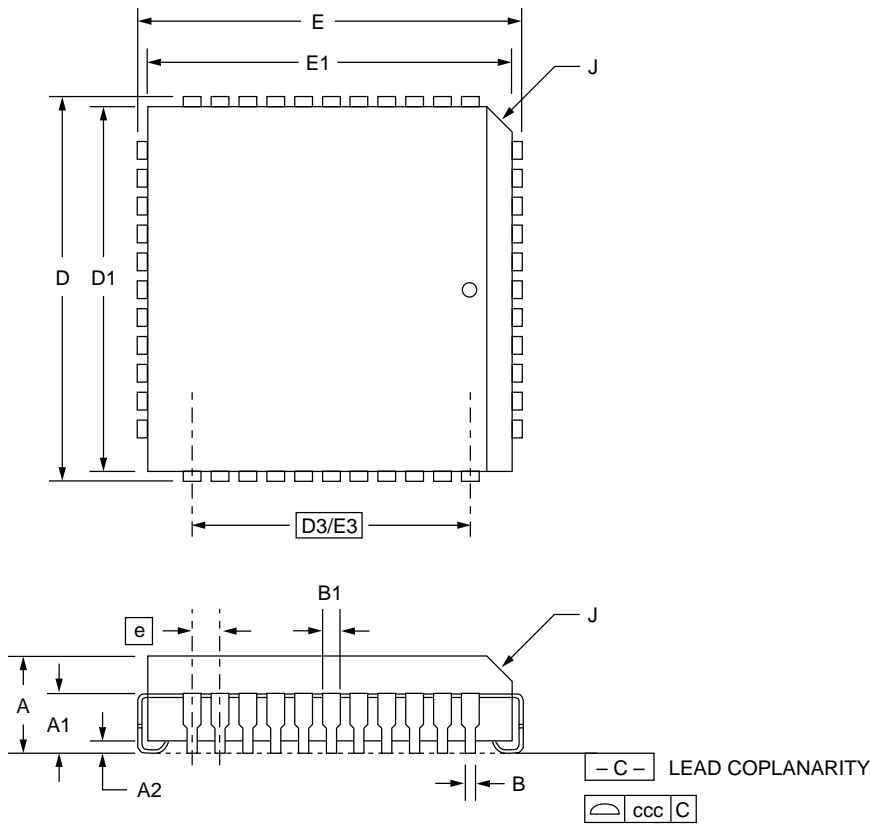

Preliminary Information

Ordering Information

Product Number	Temperature Range	Screening	Package	Package Marking
TMC2490AR2C	0°C to 70°C	Commercial	44-Lead PLCC	2490AR2C
TMC2491AR2C	0°C to 70°C	Commercial	44-Lead PLCC	2491AR2C

Preliminary Information

The information contained in this data sheet has been carefully compiled; however, it shall not by implication or otherwise become part of the terms and conditions of any subsequent sale. Raytheon's liability shall be determined solely by its standard terms and conditions of sale. No representation as to application or use or that the circuits are either licensed or free from patent infringement is intended or implied. Raytheon reserves the right to change the circuitry and any other data at any time without notice and assumes no liability for errors.

LIFE SUPPORT POLICY:

Raytheon's products are not designed for use in life support applications, wherein a failure or malfunction of the component can reasonably be expected to result in personal injury. The user of Raytheon components in life support applications assumes all risk of such use and indemnifies Raytheon Company against all damages.

Raytheon Electronics
Semiconductor Division
5580 Morehouse Drive
San Diego, CA 92121
619.457.1000
800.722.7074
Fax 619.455.6314
applications@lj.sd.ray.com